



GILLETTE GENERATORS

LIQUID COOLED DIESEL ENGINE GENERATOR SET

Model	HZ	STANDBY 125°C RISE
	60	1500 KW

60 HZ MODEL
SPMI-1.5M

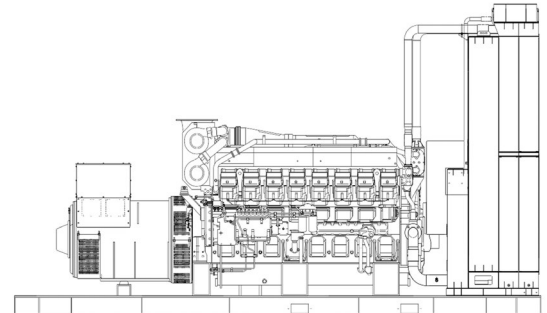

“OPEN” GEN-SET

There is no enclosure, so gen-set must be placed within a weather protected area, uninhabited by humans or animals, with proper ventilation. Silencer not supplied, as installation requirements are not known. However, this item is available as optional equipment.



All generator sets are USA prototype built and thoroughly tested. Production models are USA factory built and 100% load tested.



UL2200, UL1446, UL508, UL142, UL498, UL6200



NFPA 110, 99, 70, 37

All generator sets meet NFPA-110 Level 1, when equipped with the necessary accessories and installed per NFPA standards.



NEC 700, 701, 702, 708



NEMA ICS10, MG1, ICS6, AB1



ANSI C62.41, 27, 59, 32, 480, 40Q, 81U, 360-05



ASCE 7-22

All generator sets meet 200 MPH rating.



EPA 40CFR Part 60, 1048, 1054, 1065, 1068

GENERATOR RATINGS

GENERATOR MODEL	VOLTAGE		PH	HZ	130°C RISE STANDBY RATING		POWER LEAD CONNECTIONS
	L-N	L-L			KW/KVA	AMP	
SPMI-1.5M-3-4	277	480	3	60	1500/1875	2257	6 – Lead High Wye
SPMI-1.5M-3-16	346	600	3	60	1500/1875	1806	6 – Lead High Wye

RATINGS: All three phase gen-sets are 6 lead windings, rated at .8 power factor. 125° C “STANDBY RATINGS” are strictly for gen-sets that are used for back-up emergency power to a failed normal utility power source. This standby rating allows varying loads, with no overload capability, for the entire duration of utility power outage. All gen-set power ratings are based on temperature rise measured by resistance method as defined by MIL-STD 705C and IEEE STD 115, METHOD 6.4.4. All generators have class H (180°C) insulation system on both rotor and stator windings. All factory tests and KW/KVA charts shown above are based 130°C (standby) R/R winding temperature, within a maximum 40°C ambient condition. Generators operated at standby power ratings must not exceed the temperature rise limitation for class H insulation system, as specified in NEMA MG1-22.40. Specifications & ratings are subject to change without prior notice.

APPLICATION & ENGINEERING DATA FOR MODEL SPMI-1.5M-60 HZ

GENERATOR SPECIFICATIONS

Manufacturer..... Stamford AVK Electric Generators
 Model & Type..S7L1DC-312, 4 Pole, 6 Lead, 480V, Three Phase
S7L1DC-7, 4 Pole, 6 Lead, 600V, Three Phase
 Exciter.....Brushless, PMG excited
 Voltage Regulator.....Solid State, HZ/Volts
 Voltage Regulation.....½%, No load to full load
 Frequency.....Field convertible, 60 HZ to 50 HZ
 Frequency Regulation.....± ½% (1/2 cycle, no load to full load)
 Unbalanced Load Capability..... 100% of standby amps
 One Step Load Acceptance..... 100% of nameplate rating
 Total Stator and Load Insulation.....Class H, 180°C
 Temperature Rise..... 125°C R/R, standby rating @ 40°C amb.
 3 Ø Motor Starting @ 30% Voltage Dip (480V).....4100 kVA
 3 Ø Motor Starting @ 30% Voltage Dip (600 V).....3800 kVA
 Bearing..... 1, Pre-lubed and sealed
 Coupling.....Direct flexible disc.
 Total Harmonic Distortion..... Max 3½% (MIL-STD705B)
 Telephone Interference Factor..... Max 50 (NEMA MG1-22)
 Deviation Factor..... Max 5% (MIL-STD 405B)
 Alternator.....Self ventilating and drip-proof
 Ltd. Warranty Period..... 24 Months from start-up date or
 1000 hours use, first to occur.

GENERATOR FEATURES

- World Renown STAMFORD Generator having UL-1446 certification.
- Full generator protection with **Deep Sea 7420 MKII** controller, having UL-508 and UL-6200 certification.
- Automatic voltage regulator with over-excitation, under-frequency compensation, under-speed protection, and EMI filtering. Entire solid-state board is encapsulated for moisture protection.
- Generator power ratings are based on temperature rise, measured by resistance method, as defined in MIL-STD 705C and IEEE STD 115, Method 6.4.4.
- Power ratings will not exceed temperature rise limitation for class H insulation as per NEMA MG1-22.40.
- Insulation resistance to ground, exceeds 1.5 meg-ohm.
- Stator receives 2000 V. hi-potential test on main windings, and rotor windings receive a 1500 V. hi-potential test, as per MIL-STD 705B.
- Full amortisseur windings with UL-1446 certification.
- Complete engine-generator torsional acceptance, confirmed during initial prototype testing.
- Full load testing on all engine-generator sets, before shipping.

ENGINE SPECIFICATIONS AND APPLICATIONS DATA

ENGINE

Manufacturer.....MITSUBISHI
 Model and Type.....S16R-Y2PTAW-1, 4 cycle, liquid Cooled
 Aspiration..... Turbo After Cooler, H2O to Air
 Charged Air Cooled System..... H2O to Air
 Cylinder Arrangement..... 16 Cylinders, 60° V
 Displacement Cu. In. (Liters).....3,989 (65.37)
 Bore & Stroke In (Cm).....6.69 x 7.09 (17.0 x 18.0)
 Compression Ratio..... 14.5:1
 Main Bearings..... Tin Overlay with Babbit Backing
 Cylinder Head.....Cast Iron with overhead Cam
 Pistons.....Aluminum Alloy with Graphite Coating
 Crankshaft.....Induction Hardened, Heat Treated Forged
 Valves..... 2/ Cylinder, Heat Treated and Hardened Ex. Valves
 Governor..... Electronic, Bosch
 Frequency Regulation.....± 1/4%
 Air Cleaner.....Dry, Replaceable Cartridge
 Engine Speed..... 1800 rpm
 Max Power, bhp (kwm) Standby.....2346 (1750)
 Ltd. Warranty Period..... 2 Year or 1000 hrs, first to occur

FUEL SYSTEM

Type..... Diesel Fuel Oil (ASTM No. 2-D)
 Combustion System..... Direct Injection
 Fuel Injection Pump.....Mitsubishi PS8 Type x2
 Total Fuel Flow gal/hr (L/hr)..... 148 (560)
 Fuel Filter..... Yes
 Maximum Fuel Lift ft. (m).....10 (3)

FUEL CONSUMPTION

GAL/HR (LITER/HR)	STANDBY
100% LOAD	127 (481)
75% LOAD	96 (363.40)
50% LOAD	67.7 (256.3)

OIL SYSTEM

Type..... Full Pressure
 Oil Pan Capacity qt. (L).....200 (53)
 Oil Pan Cap. W/ filter qt. (L).....230 (60.8)
 Oil Filter.....6, Replaceable Cartridge Type

ELECTRICAL SYSTEM

Ignition System.....Electronic
 Eng. Alternator/Starter: 24 VDC, negative ground, 55 amp/hr
 Recommended battery to -18°C (0° F):(4) 12 VDC, BCI# 31,
 Max. Dimensions: 14" (L) X 6 3/4" (W) X 10" (H), with
 standard round posts. Min output 1000 CCA per battery. Battery
 tray (max. dim. at 15" L x 7" W). This model has (4) battery
 trays, (4) hold down straps, (4) sets of battery cables, and (1)
 battery charger. Installation of (4) 12VDC starting batteries
 connected in series-parallel configuration for 24VDC output is
 required as described above.

CERTIFICATIONS

All engines are EPA emissions certified. All emergency stationary diesel engines are Tier II compliant.

APPLICATION & ENGINEERING DATA FOR MODEL SPMI-1.5M-60 HZ

COOLING SYSTEM

Type of System Air to Air, Charged Air Cooler
 Coolant PumpPre-lubricated, self-sealing
 Cooling Fan Type (no. of blades)Pusher
 Fan Diameter inches (cm)..... 73.6 (187)
 Ambient Capacity of Radiator °F (°C)..... 122 (50)
 Engine Jacket Coolant Capacity gal. (L)..... 37.5 (142)
 Radiator Coolant Capacity gal. (L)..... 174.4 (660.18)
 Water Pump Capacity gpm (L/min)..... 489 (1,851)
 Heat Reject Coolant: Btu/min 36,167
 Air to Air Heat Reject, BTU/min. 8,346
 Low Radiator Coolant Level Shutdown.....Standard
 Note: Coolant temp. shut-down switch setting at 217°F (103°C) with 50/50 (water/antifreeze) mix.

COOLING AIR REQUIREMENTS

Combustion Air cfm (m³/min) 5,932 (168)
 Max Air Intake Restrictions:
 Clean Air Cleaner, mm H₂O (in.H₂O) 400 (15.7)
 Max. Temp. out of Charger Air Cooler
 @ 77° F (25°C), Amb. Air, kW (Btu/min) 635 (36,167)
 Radiator Cooling Air, SCFM (m³/min)..... 75,053 (2,124)

EXHAUST SYSTEM

Exhaust Outlet Size..... 18"
 Max. Back Pressure in KPA (in. H₂O)..... 5.9 (23.6)
 Exhaust Flow, at rated KW, CFM (m³/min)..... 15,642 (443)
 Exhaust Temp, (Stack) °F (°C) 940 (504)

SOUND LEVELS MEASURED IN dB(A)

Open Set

Level 3, Hospital Silencer.....94

Note: Open sets (no enclosure) have optional silencer system choices due to unknown job-site applications. Level 3 hospital silencer upgrade is available as an option. Sound tests are averaged from several test points and taken at 23 ft. (7 m) from source of noise at normal operation.

DERATE GENERATOR FOR ALTITUDE

3% per 1000 ft.(305m) above 3000 ft. (914m) from sea level

DERATE GENERATOR FOR TEMPERATURE

2% per 10°F(5.6°C) above 104°F (40°C)

DIMENSIONS AND WEIGHTS

Open Set

Length in (cm)..... 240 (610)
 Width in (cm)..... 102 (259)
 Height in (cm)..... 135 (343)
 3 Ø Net Weight lbs (kg)..... 34450 (15627)
 3 Ø Ship Weight lbs (kg) 34850 (15808)

DEEP SEA 7420MKII DIGITAL MICROPROCESSOR CONTROLLER

Deep Sea 7420MKII



The “7420MKII” controller is an auto start mains (utility) failure module for single gen-set applications. This controller includes a backlit LCD display which always displays the status of the engine and generator.

The 7420MKII controller will also monitor speed, frequency, voltage, current, oil pressure, coolant temp., and fuel levels. These modules have been designed to display warning and shut down status. It also includes: (11) configurable inputs • (8) configurable outputs • voltage monitoring • mains (utility) failure detection • (250) event logs • configurable timers • automatic shutdown or warning during fault detection • remote start (on load) • engine preheat • advanced metering capability • hour meter • text LCD displays • protected solid state outputs • test buttons for: stop/reset • manual mode • auto mode • lamp test • start button • power monitoring (kWh, kVAh, kVAh, kVAh) This controller includes expansion features including RS232, RS484 (using MODBUS-RTU/TCP), direct USB connection with PC, expansion optioned using DSENet for remote annunciation and remote relay interfacing for a distance of up to 3300FT. The controller software is freely downloadable from the internet and allows monitoring with direct USB cable, LAN, or by internet via the built in web interface.

STANDARD FEATURES FOR MODEL SPMI-1.5M-60 HZ

STANDARD FEATURES

CONTROL PANEL:

- Deep Sea 7420 MKII digital microprocessor with logic allows programming in the field. Controller has:
- STOP-MANUAL-AUTO modes and automatic engine shutdowns, signaled by full text LCD indicators:
 - Low oil pressure
 - High engine temp
 - Low Radiator Level
 - Three auxiliary alarms
 - Battery fail alarm
 - Engine fail to start
 - Engine over speed
 - Engine under speed
 - Over & under voltage
- Also included is tamper-proof engine hour meter

ENGINE:

- Fuel filter
- Full flow Oil filter
- Air filter
- Fuel pump
- Oil pump
- Solenoid type starter motor
- Hi-temp radiator
- Jacket water pump
- Thermostat
- Pusher fan and guard
- Exhaust manifold
- Electronic Governor
- 24 VDC battery charging alternator
- Flexible fuel and exhaust connectors
- Vibration isolators
- Open coolant recovery system with 50/50 water to anti-freeze mixture
- flexible oil & radiator hose
- Shut-down sensors for low oil pressure, high coolant temp., low coolant level, high ambient temp.

AC GENERATOR SYSTEM:

- AC generator
- PMG excited
- Brushless design
- Circuit Breaker installed and wired to gen-set
- Direct connection to engine with flex disc
- Class H, 180°C insulation
- Self ventilated
- Drip proof construction
- UL Certified

VOLTAGE REGULATOR:

- 1% Voltage regulation
- EMI filter
- Under-speed protection
- Over-excitation protection
- total encapsulation

DC ELECTRICAL SYSTEM:

- Battery tray
- Battery cables
- Battery hold down straps
- 3-stage battery charger with float, absorption, & bulk automatic charge stages

Design & specifications subject to change without prior notice. Dimensions shown are approximate. Contact Gillette for certified drawings. DO NOT USE DIMENSIONS FOR INSTALLATION PURPOSES.

