



SENTRY-PRO POWER SYSTEMS

By Gillette Generators, Inc.

MODEL
SPS-120

AIR COOLED LPG/NG, RESIDENTIAL STANDBY GEN-SET

SUBARU ENGINE-GENERATOR WITH KW POWER RATINGS RANGE

Model SERIES	STANDBY 130°C RISE			PRIME 105°C RISE	
	HZ	LPG	N.G.	LPG	N.G.
SPS-120	60	12.0	11.0	10.0	9.0

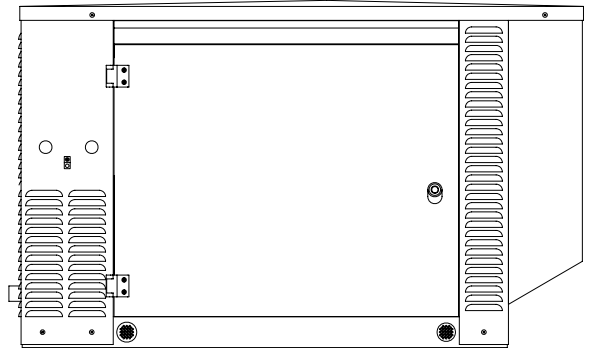

STANDARD FEATURES

- All generator sets are USA wound, built, and thoroughly tested. Complete production models are USA factory built.
- Full power capacity to start up to a 5 ton A/C unit, equipped with “Easy Start” circuitry.
- All generator sets will accept 100% rated load in one step, per NFPA-110.
- All generators are UL-1446 certified.
- Capacitor load compensated (CLC) voltage regulation for $\pm 2\%$ is standard on all gen-sets.
- Mechanical engine governor incorporates a special actuator, which allows precise $\pm 2\%$ frequency regulation, from no load to full load. Built-in dual oil coolers yield longer engine service life.
- A brushless rotating field generator design with shunt wound excitation system and available at a broad range of voltages.
- Solid state, digital microprocessor logic and ultra-bright LED, annunciation display for different engine and generator functions, plus automatic fault shutdowns; high temp., over-crank, over-speed, under-speed, low oil, and low battery.
- The heavy duty, rugged dry fueled engine is capable of delivering rated power at 3600 RPM (60 HZ).
- All generator set control systems components and accessories provide a 2-year limited warranty at time of initial start-up. Optional extended warranties are available. Generators and engines are governed by separate warranties.
- “OPEN” Generator Sets: There is no enclosure, so gen-set must be placed within a weather protected area, un-inhabited by humans or animals, with proper ventilation.
- “STANDARD” Housing: Full weather protection and average sound attenuation for normal applications.
- “SUPER-SILENT” Housing: Full weather protection and superior sound attenuation for specific low noise applications. (See “Sound Level” chart on page 3)
- New, 3 year LTD. Warranty on all Subaru dry fuel engines.

GENERATOR RATINGS

GENERATOR MODEL	VOLTAGE		PH	HZ	LIQUID PROPANE GAS FUEL				NATURAL GAS FUEL			
	L-N	L-L			130°C RISE STANDBY RATING		105°C RISE PRIME RATING		130°C RISE STANDBY RATING		105°C RISE PRIME RATING	
					KW/KVA	AMP	KW/KVA	AMP	KW/KVA	AMP	KW/KVA	AMP
SPS-120-1-1	120	240	1	60	12/12	50	10/10	42	11/11	46	9/9	38
SPS-120-3-2	120	208	3	60	12/15	42	10/12.5	35	11/13.8	38	9/11	31
SPS-120-3-3	120	240	3	60	12/15	36	10/12.5	30	11/13.8	33	9/11	27
SPS-120-3-4	277	480	3	60	12/15	18	10/12.5	15	11/13.8	17	9/11	13
SPS-120-3-5	127	220	3	60	12/15	40	10/12.5	32	11/13.8	36	9/11	29

RATINGS: All single phase gen-sets are rated at unity (1.0) power factor. All three phase gen-sets are rated at .8 power factor. 130° “STANDBY RATINGS” are strictly for gen-sets that are used for back-up emergency power to a failed normal utility power source. This standby rating allows varying loads, with no overload capability, for the entire duration of utility power outage. 105° “PRIME RATINGS” are strictly for gen-sets that provide the prime source of electric power, where normal utility power is unavailable or unreliable. A 10% overload is allowed for a total of 1 hour, within every 12 hours of operation. All gen-set power ratings are based on temperature rise measured by resistance method as defined by MIL-STD 705C and IEEE STD 115, METHOD 6.4.4. All generators have class H (180°C) insulation system on both rotor and stator windings. All factory tests and KW/KVA charts shown above are based on 130°C (standby), and 105°C (prime) R/R winding temperature, within a maximum 30°C ambient condition. Generators operated at standby power ratings must not exceed the temperature rise limitation for class H insulation system, as specified in NEMA MG1-22.40. Specifications & ratings are subject to change without prior notice.

COOLING SYSTEM

Air cooled by generator and engine suction fans. A maximum 759 CFM cooling intake air is needed for proper engine cooling.

EXHAUST SYSTEM

Residential type muffler with 58 CFM exhaust flow and an exhaust back pressure at 3600 RPM full load, of 30" water column.

ENGINE CLASS AND EMISSION LIMITS

If an engine is not handheld (trimmer, blower, etc.) and is greater than or equal to 225cc displacement, it is a Class II engine. Following are maximum emission levels for CARB & EPA Class II engines.

CALIFORNIA TIER II (GRAMS / HP-HOUR)

CLASS	DISPLACEMENT	HC+NO _x	CO
II	25 HP = 720 CC	6.8	214

USA EPA PHASE 2 (GRAMS / KILOWATT HOUR)

CLASS	DISPLACEMENT	HC+NO _x	CO
II	25 HP = 720 CC	8.0	549

1 HORSEPOWER = .746 KW

1 KW = 1.341 HORSEPOWER

Subaru engines are EPA and CARB (California Air Resources Board) certified for LPG and Natural Gas.

DERATING FACTORS

Engine horse power ratings meet SAE J1349 test codes. Reduce 3.5% for each 1000 feet, over 328 feet above seal level and 1% for every 10°F (5.65°C) rise, above 77°F (25°C). Generator specifications are in accordance with ASA, NEMA, and IEEE standards.

ACOUSTIC DATA

A= Access Doors,
B= Engine End cool air
C= Generator End hot air
& exhaust exit

Note: All tests are full load operation in standard weather with Open (no enclosure), Standard Enclosure, or Super-Silent Enclosure.

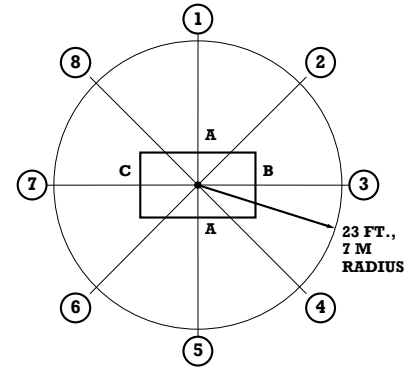

Model SPS-120 O-Open (no enclosure)

Position	1	2	3	4	5	6	7	8
dB(A)	75	74	76	74	75	77	79	77

Model SPS-120 E-Standard Enclosure

Position	1	2	3	4	5	6	7	8
dB(A)	69	69	71	68	69	72	73	72

Model SPS-120 S-Super-Silent Enclosure

Position	1	2	3	4	5	6	7	8
dB(A)	66	66	67	66	66	68	70	69

STANDARD ENCLOSURE FEATURES

- Coating Protection: (10) Independent Wash Stages for a completely clean metal base. • (1) Zinc Phosphate Metal Etching Stage. • (1) Complete Immersion into E-Coat with Baked Finish. • (1) Final Powder Coat baked on Enamel Finish. This provides UV Protection, passes UL 1000 Hour Salt Spray Tests, and gives the best protection for your investment.
- Interior sound damping preventing metal "ringing".
- Interior sound absorbing foam throughout enclosure.
- (3) Full service locking access doors.
- Hot muffler is concealed inside enclosure.

ENGINE MONITOR & OPERATION MODE FOR RESIDENTIAL STANDBY GENERATOR SETS

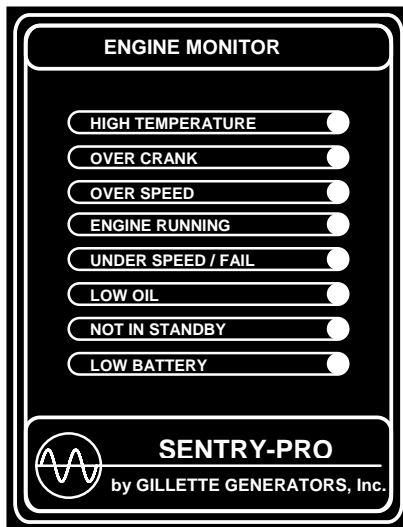

These sets use standard (2) wire start interfacing fully compatible with any dry contact start-stop system that might be installed on ATS, remote start-stop control panels, Trace inverters for controlling solar power battery arrays, etc. The start-stop signal on such equipment is utilized by the gen-set to initialize a (4) second countdown before the gen-set actually begins its first crank cycle, to

avoid start-ups due to momentary power outages.

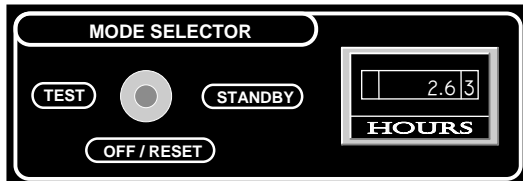

These standby gen-sets are "stand-alone" units which can work with any type ATS system or any other type sensing device, using (2) wire start-stop interfacing.

Standard features of SPS series standby sets are:

Solid State Digital Microprocessor providing automatic engine start-stop; auto shutdown for low oil, high temperature, over speed, under speed, engine fail, engine crank failure (after 3 failed crank attempts); battery charge fail; a "not in standby mode" warning indicator and a built-in (4) second engine start delay and (2) minute engine cool down delay. Timer cycles can be disabled in the field if application requirements so dictate. The "Mode Selector" switch serves (3) functions: A "Test" position (causing the gen-set to start and run indefinitely, without ATS switching the load); a "Standby" position (the system is ready to start automatically, whenever utility power fails); and an "Off/Reset" position (the engine can not start under any condition, so this is the service position and reset position when any fault is corrected). The "Engine Monitor" has (8) highly visible LED annunciators for all conditions. When mode switch is placed in "Standby" all (8) LED's will flash (3) times serving as a lamp test. The panel also includes a mainline circuit breaker and run time meter.

STANDARD AND OPTIONAL FEATURES FOR MODEL SPS-120

CONTROL PANEL:

SPS Series, automatic start-stop engine controller, utilizing solid state digital microprocessor with (8) ultra-bright LED annunciators. Panel also has main line circuit breaker, run time meter, and mode selector switch with "Test", "Standby", or "Off/Reset" positions.

ENGINE:

Full flow air cleaner and oil filter • full pressure oil system with (2) separate oil coolers • spin-on oil filter • residential muffler • 12 VDC battery charging alternator • vibration isolators • secondary dry fuel regulator with redundant dry fuel lock-off solenoid • overhead valve Subaru engine with EPA/CARB certified dry fuel system

GENERATOR:

AC generator with capacitor regulation system • single bearing • brushless design • class H, 180°C insulation system • self ventilated, drip proof construction

ELECTRICAL:

Battery tray • battery cables • battery straps • 3-stage, float type 3 amp auto battery charger

SUPPORT:

Operation, maintenance, and installation instructions
 Call 1-800-777-9639 or Fax 1-574-262-1840
 E-mail : sales@gillettegenerators.com
 Web : www.gillettegenerators.com

OPTIONAL FEATURES & ACCESSORIES

- Remote annunciator
- 3 Phase winding
- 3 Phase ATS system
- 1 Phase ATS system
- Open (no enclosure) for special applications
- Super-Silent housing w/ special sound deadening foam
- All aluminum or stainless steel weather housing
- Crankcase oil heater for faster cold weather starts

DIMENSIONAL OVERVIEW PRINT FOR MODEL SPS-120

DRAWING NOT TO SCALE & DIMENSIONS = IN [MM]

(4) LIFTING HOLES IN BASE:

1-1/2" DIA. HOLES ARE INSTALLED IN BASE, FOR LIFTING EQUIPMENT. REMOVE PLASTIC COVERS IN THESE HOLES, AND RE-INSTALL COVERS WHEN GEN-SET IS IN PLACE.

DRY FUEL CONNECTION:

LPG OR NAT. GAS CONNECTION IS LOCATED ON THE ENGINE END PANEL AS SHOWN. THERE IS A 3/4" THREADED MALE PIPE FOR CONNECTION.

ELECTRICAL CONNECTION:

THERE ARE TWO KNOCK-OUT HOLES ON THE RIGHT HAND SIDE OF GENERATOR END. BOTH HOLES ARE FOR 3/4" CONDUIT.

TOP VIEW

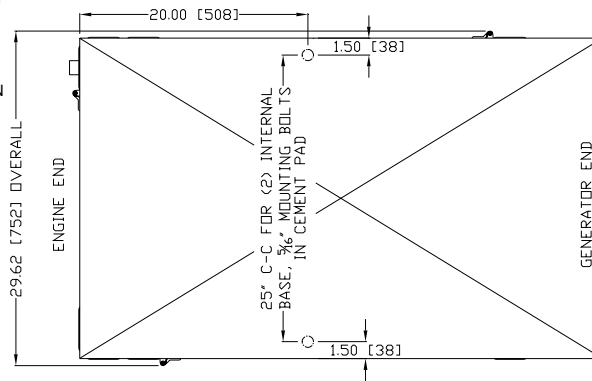

NOTE: DESIGN & SPECIFICATIONS SUBJECT TO CHANGE WITHOUT PRIOR NOTICE. DIMENSIONS SHOWN ARE FOR REFERENCE ONLY AND SHOULD NOT BE USED FOR PLANNING INSTALLATION. CONTACT GILLETTE FOR CERTIFIED DRAWINGS.

CONTROL DOOR PANEL:

THIS PANEL IS HERE TO HELP WITH INITIAL WIRING INSTALLATION AND QUICK ACCESS TO GENERATOR CONTROLS. QUALIFIED PERSONEL ONLY: UN-LOCK AND OPEN, CONTROL DOOR. REMOVE ROOF SCREW AND SLIDE BLANK PANEL DOWN AND OFF, FOR FULL WIRING ACCESS

EXHAUST CHUTE:

LOCATED IN THIS CHUTE, IS THE EXHAUST PIPE OF MUFFLER PLEASE KEEP CLEAR WHILE UNIT IS RUNNING OR HOT. DO NOT INSTALL UNIT WHERE THE EXHAUST MAY COME INTO CONTACT WITH FLAMMABLE OBJECTS. SEE PAGE 13 OF OWNERS GUIDE FOR MORE INSTALLATION INFORMATION.

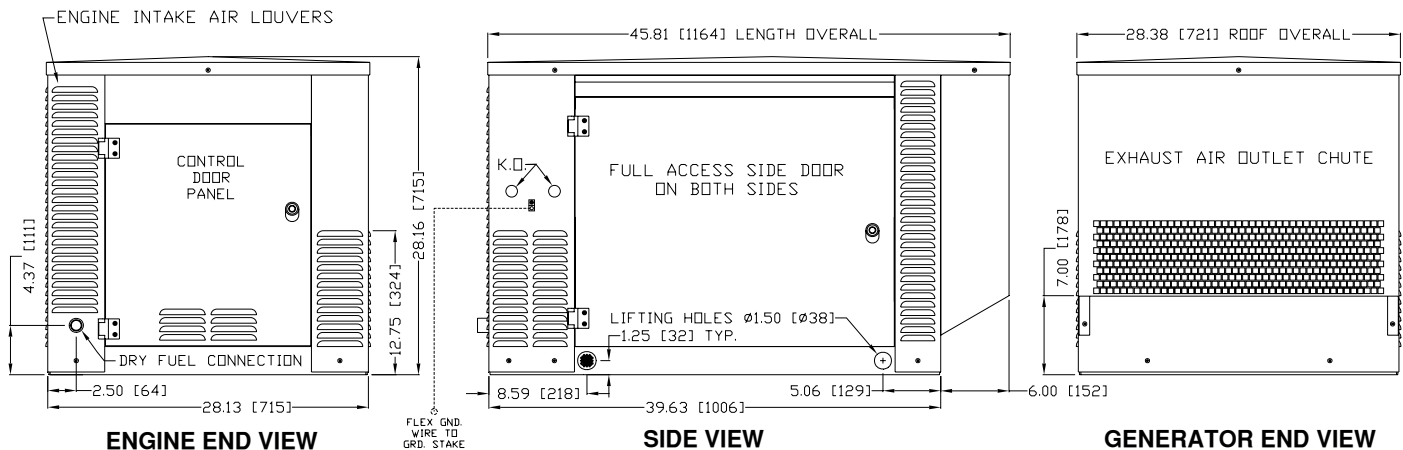

DIMENSIONS AND WEIGHTS

FOR STAINLESS STEEL AND STAINLESS STEEL HOUSINGS	Open Set	Standard Enclosure	Super-Silent Enclosure
Length in (cm)	44 (112)	50 (127)	50 (127)
Width in (cm)	28 (71)	30 (76)	30 (76)
Height in (cm)	23 (59)	28 (71)	28 (71)
Net Weight lbs (kg)	380 (172)	530 (240)	555 (251)
Ship Weight lbs (kg)	430 (195)	580 (263)	600 (272)
REDUCTION IN WEIGHT FOR ALUMINUM HOUSING	N/A	-70(32)	-70(32)

DISTRIBUTED BY: